

DRG. No. Y34GH001/1
 DRG. REF.

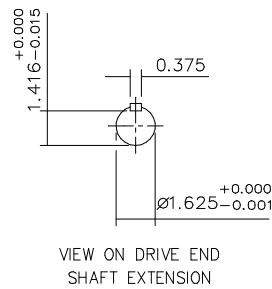
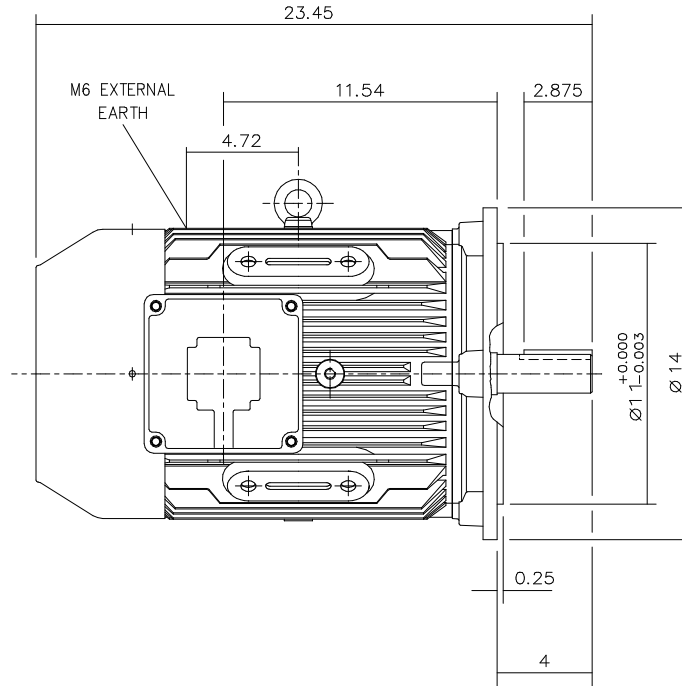
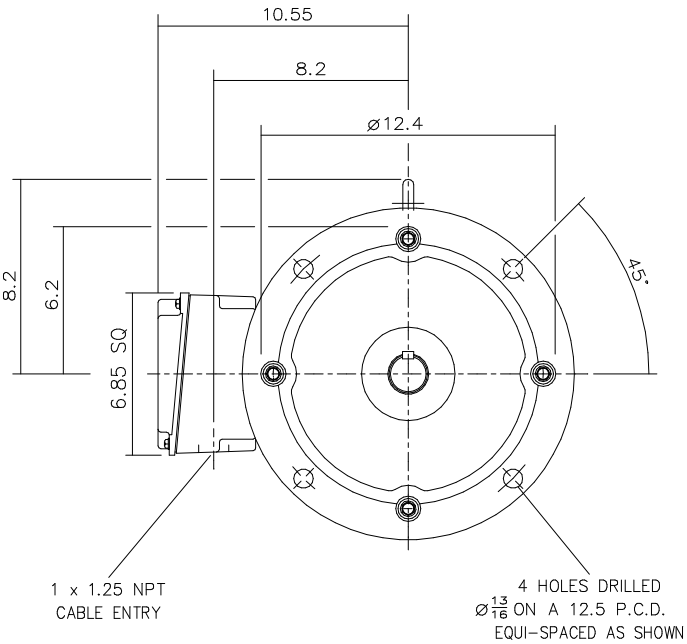

DRAIN HOLES: - WHEN TERMINAL BOX IS MOVED FROM STANDARD POSITION THEY WILL NEED TO BE PLUGGED AND RE-LOCATED ELSEWHERE - IF REQUIRED
 TERMINAL BOX POSITION : - CAN BE ARRANGED AT EITHER 9, 12 OR 3 O'CLOCK.
 CONDUIT ENTRIES: - TERMINAL BOX CAN BE ROTATED AT 90° INTERVALS (CONDUIT ENTRY POSITION SHOWN FOR ILLUSTRATION ONLY).

CUSTOMER		
ORDER No.		
PART No.		
OUR ORDER No.		
FRAME SIZE		
KW.	RPM.	
Hz	PHASE	
VOLTS	POLES	
BRGS.	DE.	NDE.
MOTOR NETT WT.	Kg.	
SPECIAL REMARKS		

ALL DIMENSIONS IN INCHES



BROOK CROMPTON

Huddersfield, HD1 3LJ
 ENGLAND

SHEET SIZE **A3** TITLE OUTLINE DIMENSION DRAWING W CAST IRON TOTALLY ENCLOSED FAN COOLED 254/6T FRAME 'D' INCH FLANGE MOUNTED MOTOR

	NAME	DATE
DRAWN	RR	19-10-00
CHECKED	VLS	19-10-00
SCALE	1 : 5	

DRG. No.	Y34GH001/1	
DRG. REF.		
REVISION:	VLS	DATE 17-07-02