

DRG. No. Y33GE001/1  
 DRG. REF.

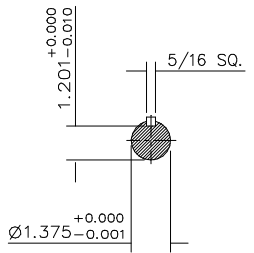

SECTION THROUGH 'X'

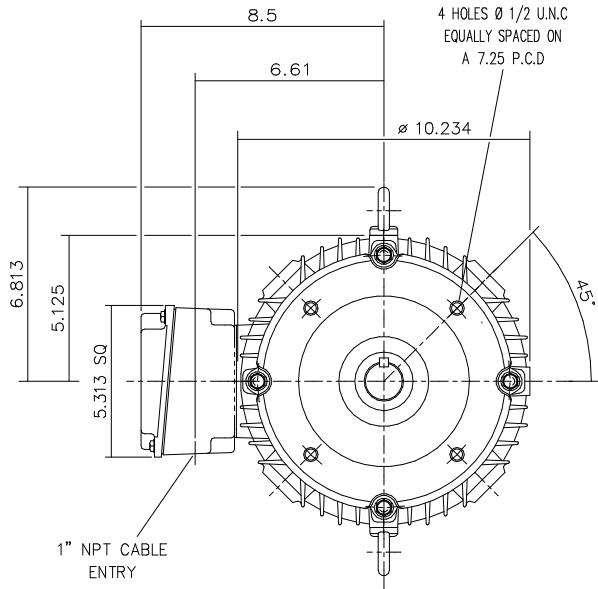
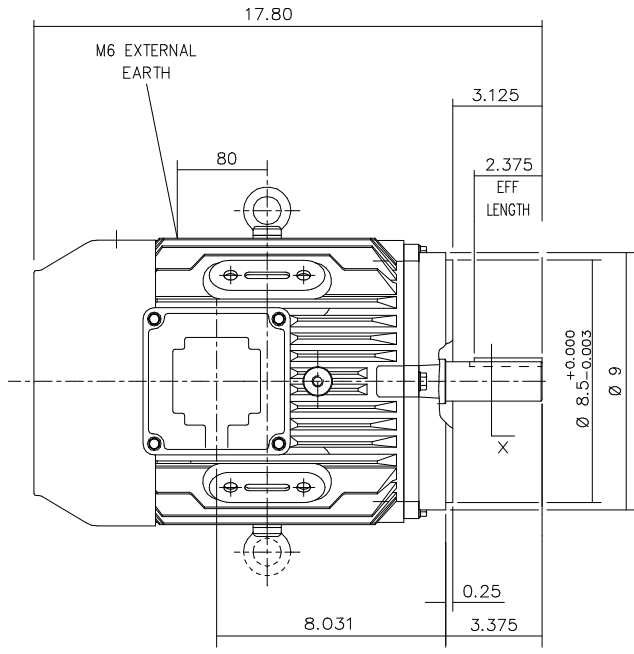

TERMINAL BOX POSITION : - CAN BE ARRANGED AT EITHER 9, 12 OR 3 O'CLOCK.  
 STANDARD TERMINAL BOX POSITION IS 9 O'CLOCK AS SHOWN.  
 CONDUIT ENTRIES: - TERMINAL BOX CAN BE ROTATED AT 90° INTERVALS  
 (CONDUIT ENTRY POSITION SHOWN FOR ILLUSTRATION ONLY).

CUSTOMER
ORDER No.
SERIAL No.
FRAME SIZE
KW. RPM.
Hz PHASE
VOLTS POLES
BRGS. DE. NDE.
MOTOR NETT WT. Kg.
SPECIAL REMARKS

ALL DIMENSIONS IN INCHES

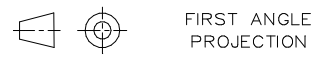

FIRST ANGLE PROJECTION

**BROOK CROMPTON**

Huddersfield, HD1 3LJ  
 ENGLAND

SHEET SIZE A3	TITLE OUTLINE DIMENSION DRAWING W CAST IRON TOTALLY ENCLOSED FAN COOLED 213/215T FRAME C FACE MOUNTED MOTOR

	NAME	DATE
DRAWN	VLS	30/11/00
CHECKED	RR	30-11-00
SCALE	1 : 4	

DRG. No.	Y33GE001/1	
DRG. REF.		
REVISION:	VLS	DATE 18-07-02