

DRG. No. Y32GE001/0
 DRG. REF.

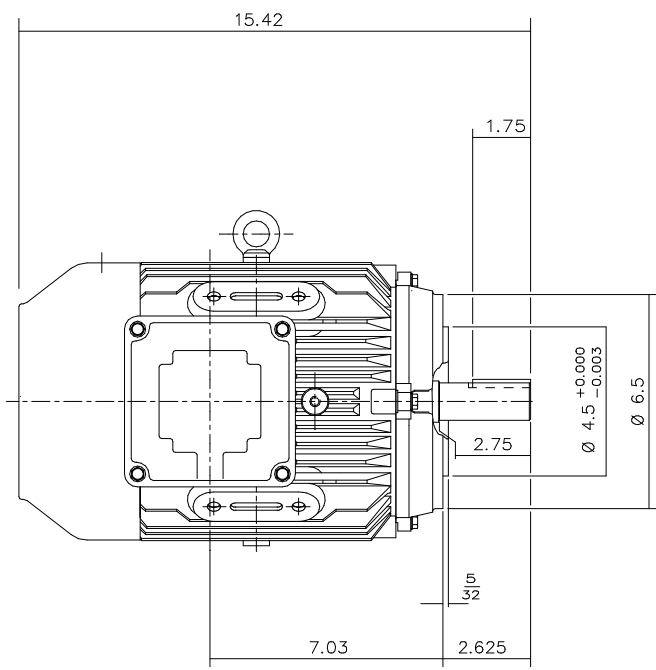

1 x 0.75" N.P.T
 CABLE ENTRY

VIEW ON SHAFT EXTENSION.

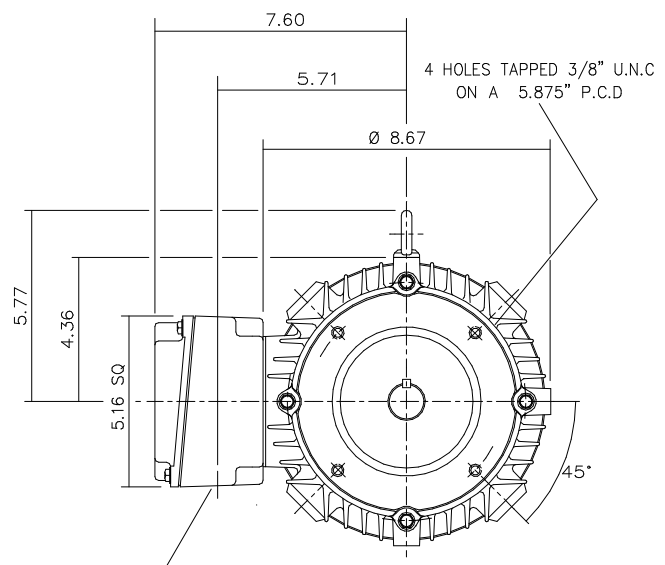
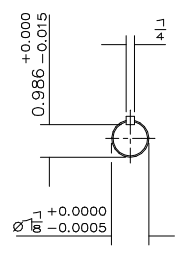

TERMINAL BOX POSITION: - CAN BE ARRANGED AT EITHER 9,12 OR 3 O'CLOCK
 STANDARD TERMINAL BOX POSITION IS 9 O'CLOCK AS SHOWN
 CONDUIT ENTRIES: - TERMINAL BOX CAN BE ROTATED AT 90° INTERVALS
 (CONDUIT ENTRY POSITION SHOWN FOR ILLUSTRATION ONLY)

CUSTOMER		
ORDER No.		
SERIAL No.		
FRAME SIZE		
KW.	RPM.	
Hz	PHASE	
VOLTS	POLES	
BRGS.	DE.	NDE.
MOTOR NETT WT.	Kg.	
SPECIAL REMARKS		

ALL DIMENSIONS IN INCHES

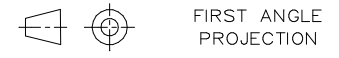

BROOK CROMPTON

Huddersfield, HD1 3LJ
 ENGLAND

SHEET SIZE A3	TITLE	OUTLINE DIMENSION DRAWING W CAST IRON TOTALLY ENCLOSED FAN COOLED 182/4 FRAME FACE MOUNTED MOTOR - 4.5" SPIGOT

	NAME	DATE
DRAWN	VLS	02-02-01
CHECKED	RR	02-02-01
SCALE	1: 3.5	

DRG. No.	Y32GE001/0	
DRG. REF.		
REVISION:		DATE