

DRG. No. W35GH003/1
 DRG. REF.

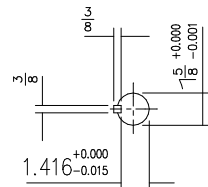
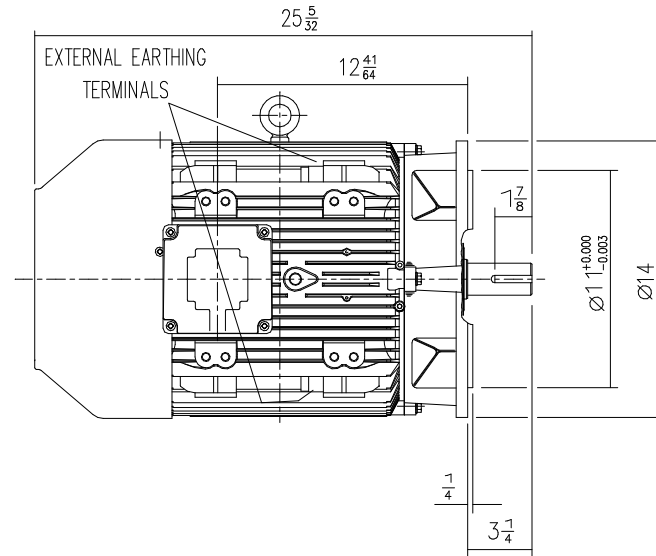
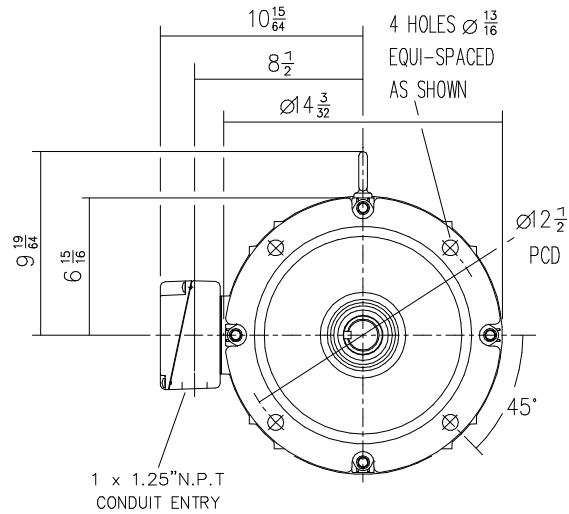

VIEW ON DRIVE END
EXTENSION

DRAIN HOLES: - WHEN TERMINAL BOX IS MOVED FROM STANDARD POSITION THEY WILL NEED TO BE PLUGGED AND RE-LOCATED ELSEWHERE - IF REQUIRED.
 TERMINAL BOX POSITION: - CAN BE ARRANGED AT EITHER 9, 12, OR 3 O'CLOCK.
 STANDARD TERMINAL BOX POSITION IS 9 O'CLOCK AS SHOWN.
 CONDUIT ENTRIES: - TERMINAL BOX CAN BE ROTATED AT 90° INTERVALS.
 (CONDUIT ENTRY POSITION SHOWN FOR ILLUSTRATION ONLY).

CUSTOMER		
ORDER No.		
PART No.		
OUR ORDER No.		
FRAME SIZE		
KW.	RPM.	
Hz	PHASE	
VOLTS	POLES	
BRGS.	DE.	NDE.
MOTOR NETT WT.	Kg.	
SPECIAL REMARKS		

ALL DIMENSIONS IN INCHES
 FIRST ANGLE PROJECTION

BROOK CROMPTON

Huddersfield, HD1 3LJ
ENGLAND

SHEET TITLE
 SIZE A3 OUTLINE DIMENSION DRAWING 'W' ALUMINIUM TOTALLY ENCLOSED FAN COOLED
 284/6TS FRAME 'D' INCH FLANGE MOUNTED MOTOR (2 POLE)

	NAME	DATE
DRAWN	RR	27.07.01
CHECKED	DH	27.07.01
SCALE	1:6	

DRG. No.	W35GH003/1		
DRG. REF.			
REVISION:	DH	DATE	21-01-04