

DRG. No. W33GD001/2
 DRG. REF.

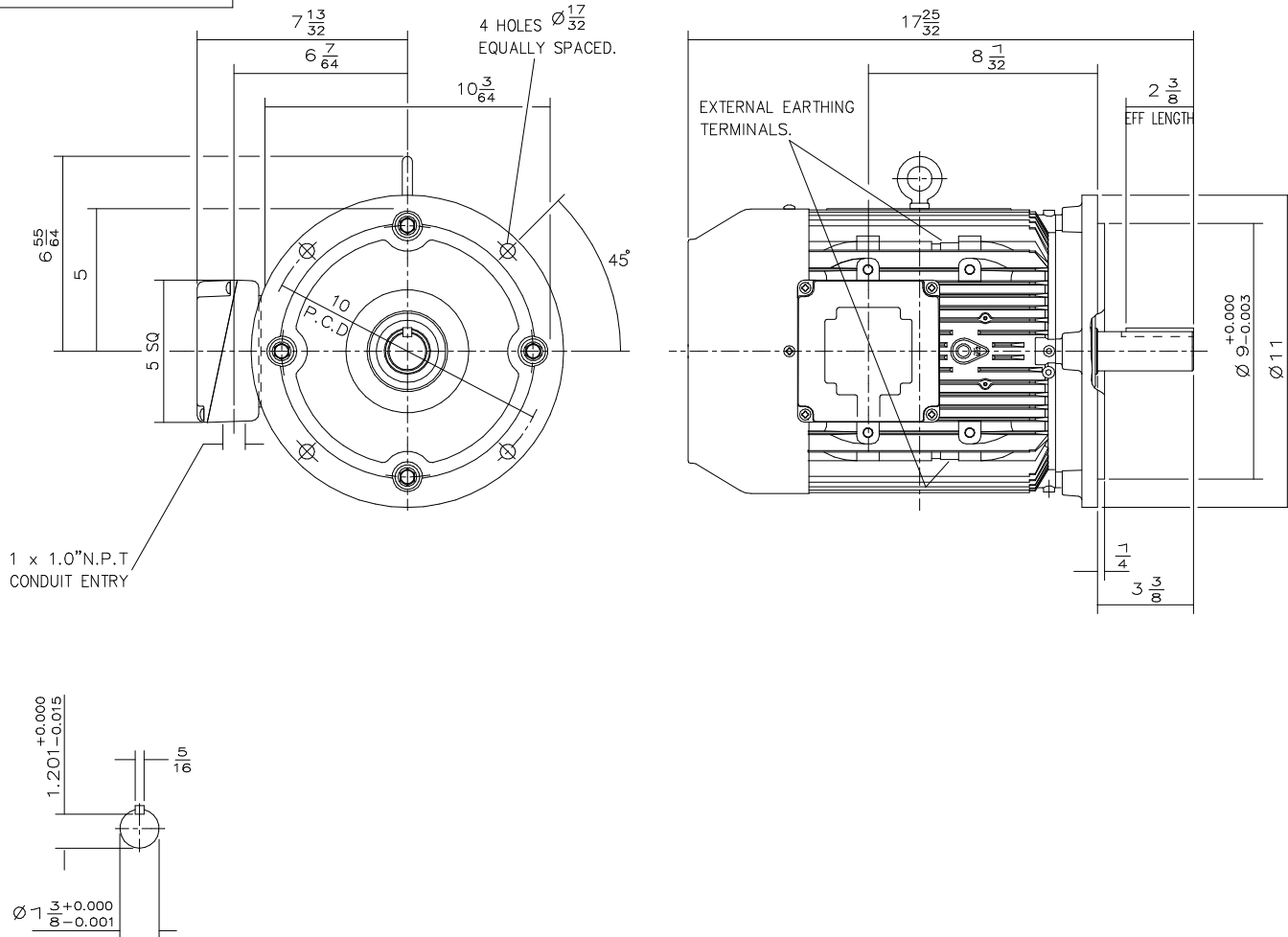

TERMINAL BOX POSITION:- CAN BE ARRANGED EITHER AT 9,12 OR 3 O'CLOCK.
 STANDARD TERMINAL BOX POSITION IS 9 O'CLOCK AS SHOWN.
 CONDUIT ENTRIES:- TERMINAL BOX CAN BE ROTATED AT 90° INTERVALS
 (CONDUIT POSITION SHOWN FOR ILLUSTRATION ONLY).

CUSTOMER		
ORDER No.		
PART No.		
OUR ORDER No.		
FRAME SIZE		
KW.	RPM.	
Hz	PHASE	
VOLTS	POLES	
BRGS.	DE.	NDE.
MOTOR NETT WT.		Kg.
SPECIAL REMARKS		

ALL DIMENSIONS IN INCHES.



FIRST ANGLE PROJECTION

BROOK CROMPTON

Huddersfield, HD1 3LJ ENGLAND

SHEET SIZE A3 TITLE OUTLINE DIMENSION DRAWING W ALUMINIUM TOTALLY ENCLOSED FAN COOLED 213/5T 'D' INCH FLANGE MOUNTED MOTOR.

	NAME	DATE
DRAWN	PAD	15-08-97
CHECKED	DRM	15-08-97
SCALE	1 : 4	

DRG. No.	W33GD001/2		
DRG. REF.			
REVISION:	RR	DATE	25-07-01