

DRG. No. W35GE000/1
 DRG. REF.

CUSTOMER
 ORDER No.
 PART No.
 OUR ORDER No.
 FRAME SIZE
 KW. RPM.
 Hz PHASE
 VOLTS POLES
 BRGS. DE. NDE.
 MOTOR NETT WT. Kg.
 SPECIAL REMARKS

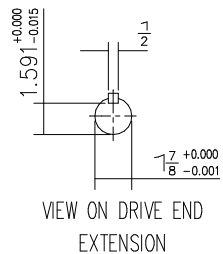
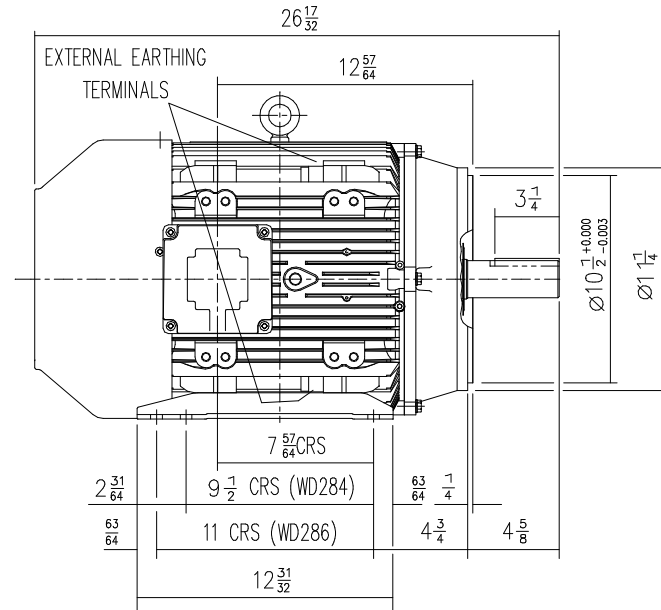
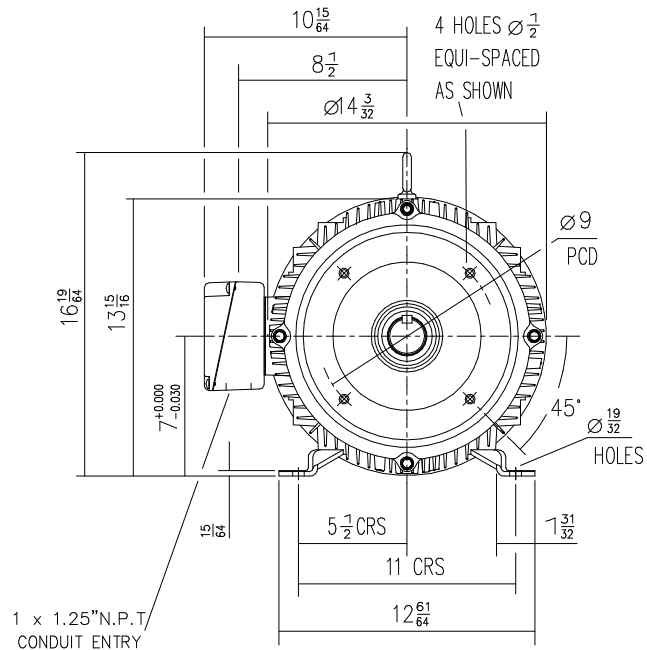

DRAIN HOLES: - WHEN TERMINAL BOX IS MOVED FROM STANDARD POSITION THEY WILL NEED TO BE PLUGGED AND RE-LOCATED ELSEWHERE - IF REQUIRED.
 TERMINAL BOX POSITION: - CAN BE ARRANGED AT EITHER 9, 12, OR 3 O'CLOCK.
 STANDARD TERMINAL BOX POSITION IS 9 O'CLOCK AS SHOWN.
 CONDUIT ENTRIES: - TERMINAL BOX CAN BE ROTATED AT 90° INTERVALS.
 (CONDUIT ENTRY POSITION SHOWN FOR ILLUSTRATION ONLY).

ALL DIMENSIONS IN INCHES



BROOK CROMPTON

Huddersfield, HD1 3LJ
 ENGLAND

SHEET TITLE
 SIZE A3
 OUTLINE DIMENSION DRAWING 'W' ALUMINIUM TOTALLY ENCLOSED FAN COOLED 284/6T FRAME 'C' INCH FACE WITH FEET MOUNTED MOTOR.

	NAME	DATE
DRAWN	MI	23.11.95
CHECKED	JWD	23.11.95
SCALE	1 : 6	

DRG. No.	W35GE000/1		
DRG. REF.			
REVISION:	RR	DATE	25/07/01