

TWO LIFTING LUGS
DIAGONALLY
OPPOSITE.

4 HOLES ϕ .8125
EQUALLY SPACED
ON 16 P.C.D.

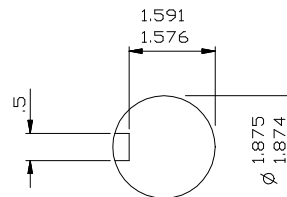
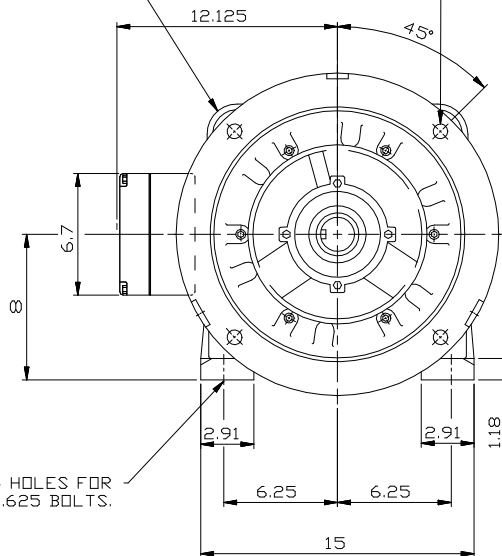

SECTION THROUGH
SHAFT EXTENSION.
(SCALE 1:2).

NOTE:-
CABLE ENTRY CAN BE
SUPPLIED IN ANY ONE OF FOUR
POSITIONS AT 90 ° INTERVALS.

NOTE1
STANDARD MACHINES ARE ARRANGED FOR HORIZONTAL OVERHUNG MOUNTING.
CUSTOMERS SHOULD NOTIFY US WHEN ORDERING IF VERTICAL MOUNTING
IS REQUIRED. IF VERTICAL, THE MOTOR THRUST BEARING MUST
NOT BE ALLOWED TO TAKE ANY LOAD OTHER THAN THE WEIGHT OF
THE ROTOR WITHOUT OUR APPROVAL.

CUSTOMER	
ORDER No.	
SERIAL No.	
FRAME SIZE	
HP	R.P.M.
Hz	PHASE 3
VOLTS	POLES
BRGS. D.E	N.D.E
MOTOR NETT. WT.	Kg.
INSULATION CLASS	
TEMPERATURE RISE °C	
DESIGN AMBIENT TEMPERATURE °C	
HEATER WATTS & VOLTS (IF FITTED)	
WATTS,	VOLTS

REMARKS

BROOK CROMPTON
PRELIMINARY

Large Industrial Motors
Guisley, LEEDS LS20 9NZ

ALL DIMENSIONS IN INCHES

THIRD ANGLE PROJECTION

BROOK CROMPTON

Large Industrial Motors
GUISLEY, LEEDS, LS20 9NZ.

NOTE1
ENDPLAY WILL BE PROVIDED FOR ENDTHRUST PROTECTION WHEN CUSTOMERS NOTIFY US OF THEIR INTENTION TO USE RIGID COUPLINGS AND DRIVEN MACHINES WITHOUT ENDPLAY.

OUTLINE DIMENSIONS OF STANDARD FLANGE MOUNTED INCH A.C MOTOR TO NEMA STD. MG1. TOTALLY ENCLOSED FAN VENTILATED. TERMINAL BOX MOUNTED ON LEFT HAND SIDE VIEWED ON DRIVE END. FRAME SIZE. W-DF324TSD-X (2 POLE ONLY).

SCALE	1:6	DATE
DRAWN	PAH	17.12.99
CHECKED	JML	17.12.99
APPROVED	JML	17.12.99

DRG. No.	M21648
REVISION:	DATE