

CABLE ENTRY  
SCREWED 2" N. P. T.

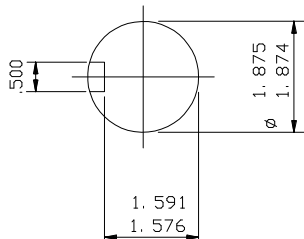

ENLARGED VIEW OF  
SHAFT EXTENSION  
(SCALE 1: 2)

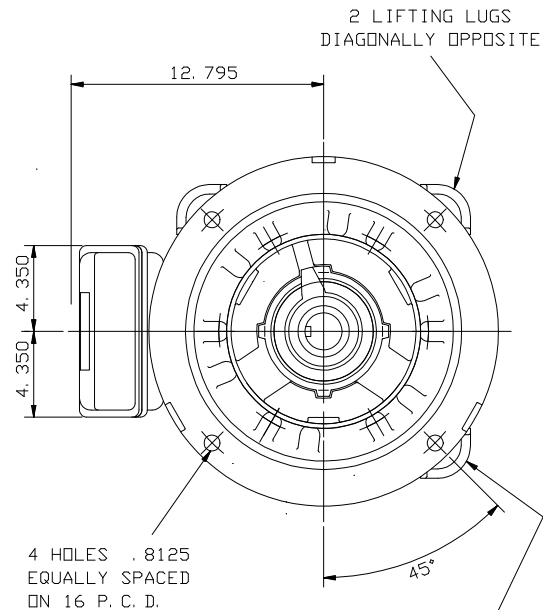

THIS LIFTING LUG FITTED  
ONLY WHEN MOTOR IS  
VERTICALLY MOUNTED.

NOTE: -  
CABLE ENTRY CAN BE SUPPLIED IN  
ANY ONE OF FOUR POSITIONS AT  
90° INTERVALS.

NOTE: -  
STANDARD MACHINES ARE ARRANGED FOR HORIZONTAL OVERHUNG MOUNTING.  
CUSTOMERS SHOULD NOTIFY US WHEN ORDERING IF VERTICAL MOUNTING  
IS REQUIRED. IF VERTICAL, THE MOTOR THRUST BEARING MUST NOT BE  
ALLOWED TO TAKE ANY LOAD OTHER THAN THE WEIGHT OF THE ROTOR  
WITHOUT OUR APPROVAL.

OUTLINE DIMENSIONS OF STANDARD D FLANGE MOUNTED INCH A. C. MOTOR  
TO NEMA STD. MG1. TOTALLY ENCLOSED FAN COOLED.  
FITTED WITH TOP MOUNTED TERMINAL BOX  
FRAME SIZE :- W-DF324TS-N (2 POLE)

SCALE	1/6	DATE
DRAWN	B. J. T.	22.2.94
CHECKED	B. J. T.	22.2.94
APPROVED	I. J. W.	22.2.94

CUSTOMER		
ORDER No.		
SERIAL No.		
FRAME SIZE		
HP	RPM.	
Hz	PHASE	3
VOLTS	POLES	
BRGS.	DE.	NDE.
MOTOR NETT. WT.		Kg.
INSULATION CLASS		
TEMPERATURE RISE °C		
DESIGN AMBIENT TEMPERATURE °C		
HEATER WATTS & VOLTS		
WATTS,	VOLTS	

REMARKS

**BROOK CROMPTON**  
PRELIMINARY

Large Industrial Motors  
Guiseley, LEEDS LS20 9NZ

ALL DIMENSIONS IN INCHES



**BROOK CROMPTON**

Large Industrial Motors  
GUISELEY, LEEDS, LS20 9NZ.

NOTE 1  
\* ENDPLAY WILL BE PROVIDED FOR ENDTHRUST  
PROTECTION WHEN CUSTOMERS NOTIFY US OF THEIR  
INTENTION TO USE RIGID COUPLINGS AND DRIVEN  
MACHINES WITHOUT ENDPLAY.

DRG. No.	M9564
REVISION:	DATE