

CABLE ENTRY
SCREWED 3" N. P. T.

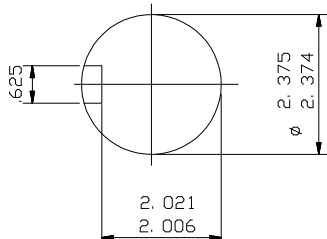

ENLARGED VIEW OF
SHAFT EXTENSION.
(SCALE 1:2)

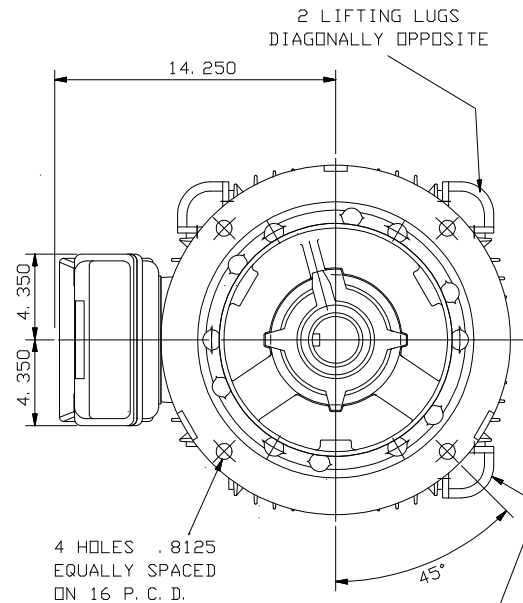

2 LIFTING LUGS
DIAGONALLY OPPOSITE

4 HOLES .8125
EQUALLY SPACED
ON 16 P. C. D.

THIS LIFTING LUG FITTED
ONLY WHEN MOTOR IS
VERTICALLY MOUNTED.

NOTE: -
CABLE ENTRY CAN BE SUPPLIED IN
ANY ONE OF FOUR POSITIONS AT
90° INTERVALS.

NOTE: -
STANDARD MACHINES ARE ARRANGED FOR HORIZONTAL OVERHUNG MOUNTING.
CUSTOMERS SHOULD NOTIFY US WHEN ORDERING IF VERTICAL MOUNTING
IS REQUIRED. IF VERTICAL, THE MOTOR THRUST BEARING MUST NOT BE
ALLOWED TO TAKE ANY LOAD OTHER THAN THE WEIGHT OF THE ROTOR
WITHOUT OUR APPROVAL.

CUSTOMER		
ORDER No.		
SERIAL No.		
FRAME SIZE		
HP	RPM.	
Hz	PHASE 3	
VOLTS	POLES	
BRGS.	DE.	NDE.
MOTOR NETT. WT.	Kg.	
INSULATION CLASS		
TEMPERATURE RISE °C		
DESIGN AMBIENT TEMPERATURE °C		
HEATER WATTS & VOLTS		
WATTS,		VOLTS

REMARKS		
 <p>Large Industrial Motors Guiseley, LEEDS LS20 9NZ</p>		

ALL DIMENSIONS IN INCHES



**BROOK
CROMPTON**

Large Industrial Motors
GUISELEY, LEEDS, LS20 9NZ.

NOTE 1
* ENDPLAY WILL BE PROVIDED FOR ENDTHRUST
PROTECTION WHEN CUSTOMERS NOTIFY US OF THEIR
INTENTION TO USE RIGID COUPLINGS AND DRIVEN
MACHINES WITHOUT ENDPLAY.

OUTLINE DIMENSIONS OF STANDARD D FLANGE MOUNTED INCH A. C. MOTOR
TO NEMA STD. MG1. TOTALLY ENCLOSED FAN COOLED.
FITTED WITH SIDE MOUNTED TERMINAL BOX
FRAME SIZE :- W-DF364T-N (4 POLE UP)

SCALE	1:6	DATE
DRAWN	B.J.T.	11.2.94
CHECKED	B.J.T.	11.2.94
APPROVED	I.J.W.	11.2.94

DRG. No.	M9532	
REVISION:		DATE