

2 LIFTING LUGS  
DIAGONALLY OPPOSITE

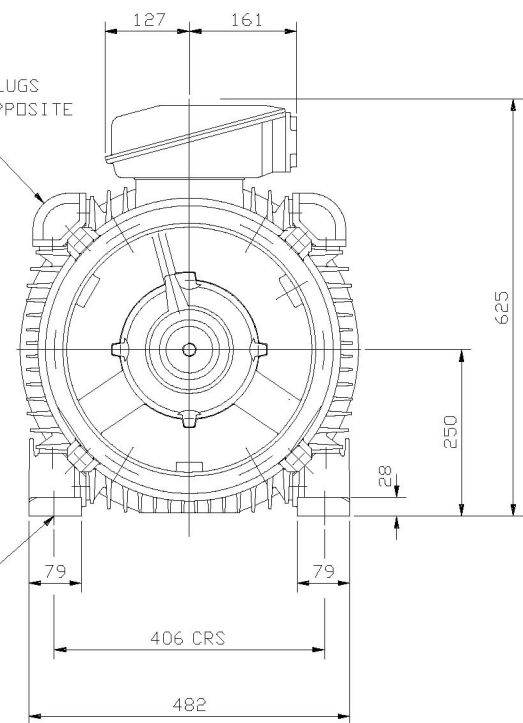

4 HOLES FOR M20 BOLTS

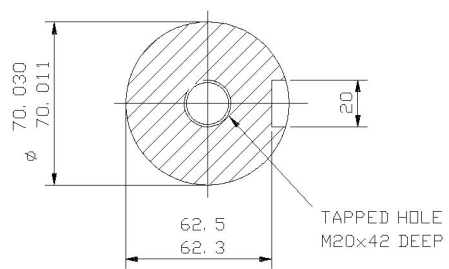

SECTION THROUGH  
SHAFT EXTENSION  
(SCALE 1: 2)

TAPPED HOLE  
M20x42 DEEP

NOTE: -  
TERMINAL BOX CAN BE SIDE MOUNTED  
(LEFT OR RIGHT) BY REFITTING FEET  
90° IN APPROPRIATE DIRECTION.  
CABLE ENTRY CAN BE SUPPLIED IN  
ANY ONE OF FOUR POSITIONS AT  
90° INTERVALS.

CUSTOMER		
ORDER No.		
SERIAL No.		
FRAME SIZE		
kW	RPM.	
Hz	PHASE 3	
VOLTS	POLES	
BRGS.	DE.	NDE.
MOTOR NETT. WT.	Kg.	
INSULATION CLASS		
TEMPERATURE RISE	° C	
DESIGN AMBIENT TEMPERATURE	° C	
HEATER WATTS & VOLTS		
	WATTS,	VOLTS

REMARKS

ALL DIMENSIONS IN MILLIMETRES

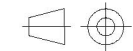

FIRST ANGLE  
PROJECTION

**BROOK  
CROMPTON**

NOTE 1  
2.5 ENDPLAY WILL BE PROVIDED FOR ENDTHRUST  
PROTECTION WHEN CUSTOMERS NOTIFY US OF THEIR  
INTENTION TO USE RIGID COUPLINGS AND DRIVEN  
MACHINES WITHOUT ENDPLAY.

OUTLINE DIMENSIONS OF STANDARD FOOT MOUNTED METRIC A. C. MOTOR  
TOTALLY ENCLOSED FAN VENTILATED.  
FITTED WITH TOP MOUNTED TERMINAL BOX  
FRAME SIZE : - W-DF250M (4 POLE UP)

SCALE	1:7	DATE
DRAWN		
CHECKED		
APPROVED		

DRG. No.	
REVISION:	
DATE	