

DRG. No. Y28GP004/1
 DRG. REF.

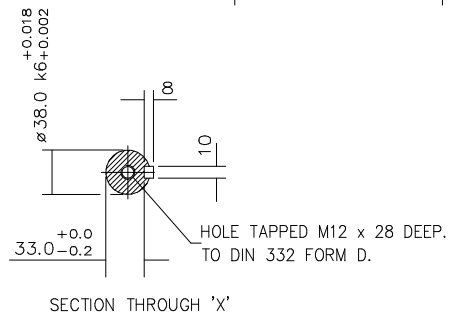
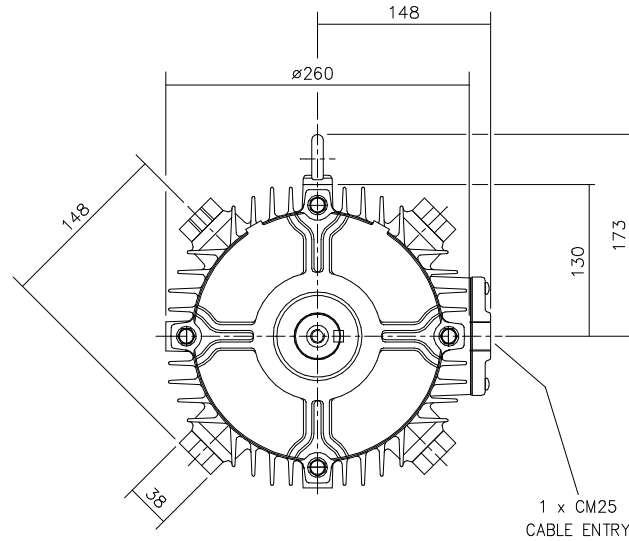
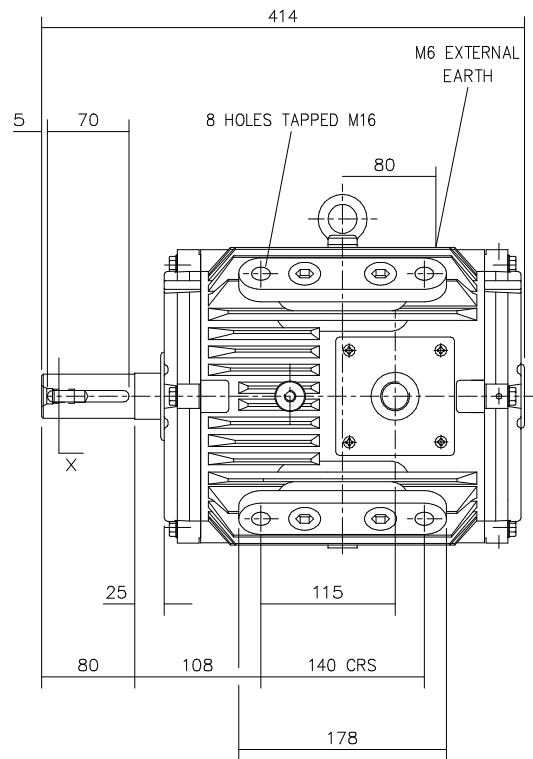

TERMINAL PLATE POSITION : - CAN BE ARRANGED AT EITHER 9, 12 OR 3 O'CLOCK.
 STANDARD TERMINAL PLATE POSITION IS 3 O'CLOCK AS SHOWN.
 (CONDUIT ENTRY POSITION SHOWN FOR ILLUSTRATION ONLY).

CUSTOMER		
ORDER No.		
PART No.		
OUR ORDER No.		
FRAME SIZE		
KW.	RPM.	
Hz	PHASE	
VOLTS	POLES	
BRGS.	DE.	NDE.
MOTOR NETT WT.		Kg.
SPECIAL REMARKS		

ALL DIMENSIONS IN MILLIMETRES.



BROOK CROMPTON

Huddersfield, HD1 3LJ
 ENGLAND

SHEET TITLE
 SIZE A3 OUTLINE DIMENSION DRAWING W CAST IRON TOTALLY ENCLOSED NO FAN
 132S/M FRAME PAD MOUNTED MOTOR - NO TERMINAL BOX

	NAME	DATE
DRAWN	DH	16-01-01
CHECKED	RR	16-01-01
SCALE	1 : 4	

DRG. No.	Y28GP004/1		
DRG. REF.			
REVISION:	VLS	DATE	18-07-02