

DRG. No. Y12GD002/4
 DRG. REF.

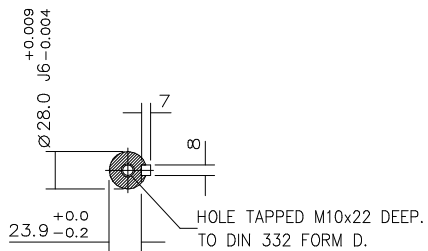
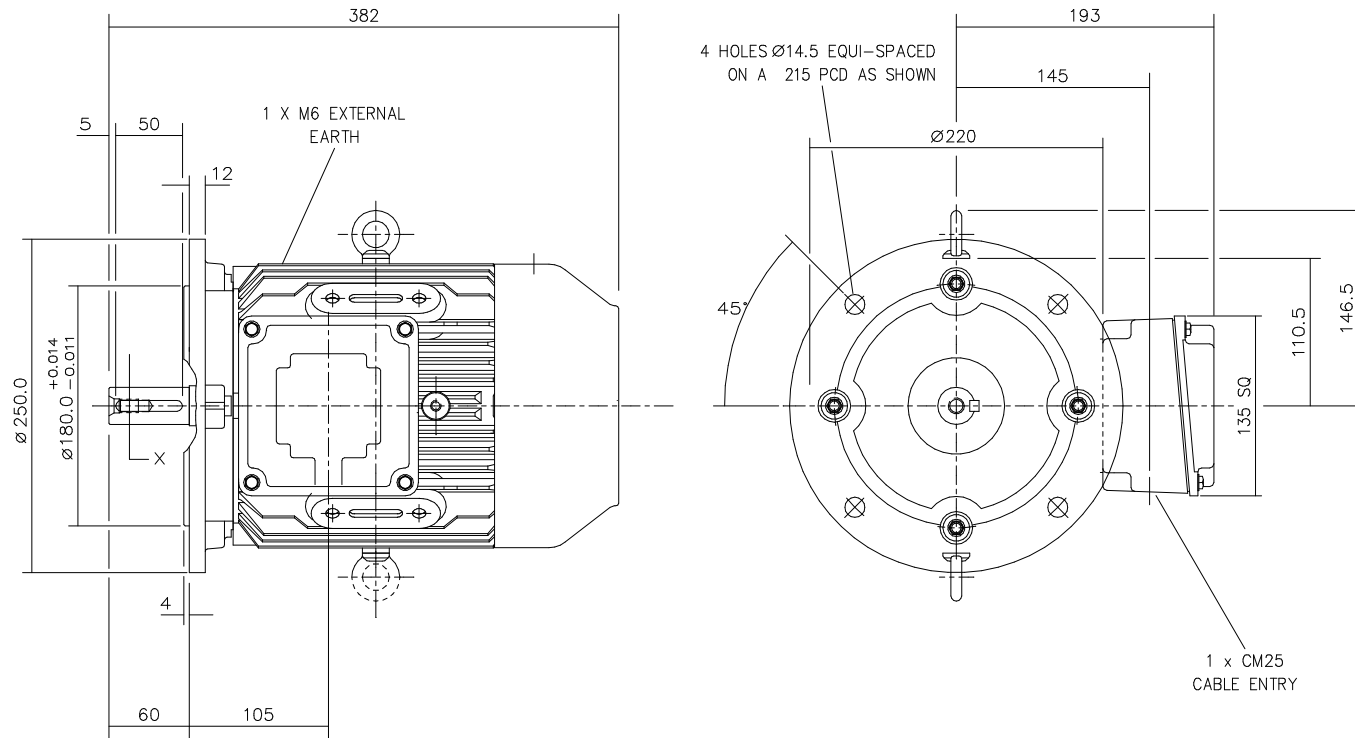

SECTION THROUGH 'X'

TERMINAL BOX POSITION:- CAN BE ARRANGED AT EITHER 9,12 OR 3 O'CLOCK.
 STANDARD TERMINAL BOX POSITION IS 3 O'CLOCK AS SHOWN.
 CONDUIT ENTRIES:- TERMINAL BOX CAN BE ROTATED AT 90° INTERVALS
 (CONDUIT ENTRY POSITION SHOWN FOR ILLUSTRATION ONLY).

CUSTOMER		
ORDER No.		
PART No.		
OUR ORDER No.		
FRAME SIZE		
KW.	RPM.	
Hz	PHASE	
VOLTS	POLES	
BRGS.	DE.	NDE.
MOTOR NETT WT.	Kg.	
SPECIAL REMARKS		

ALL DIMENSIONS IN MILLIMETRES.



BROOK CROMPTON

Huddersfield, HD1 3LJ
 ENGLAND

SHEET TITLE
 SIZE A3 OUTLINE DIMENSION DRAWING W CAST IRON TOTALLY ENCLOSED FAN COOLED
 112M FRAME D FLANGE MOUNTED MOTOR

	NAME	DATE
DRAWN	RR	12-01-00
CHECKED	VLS	12-01-00
SCALE	1: 3.5	

DRG. No.	Y12GD002/4		
DRG. REF.			
REVISION:	RR	DATE	27-06-02