

DRG. No. W28GP000/3

DRG. REF.

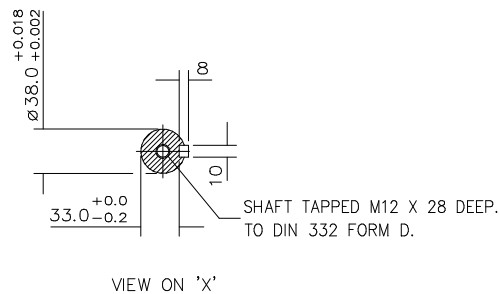
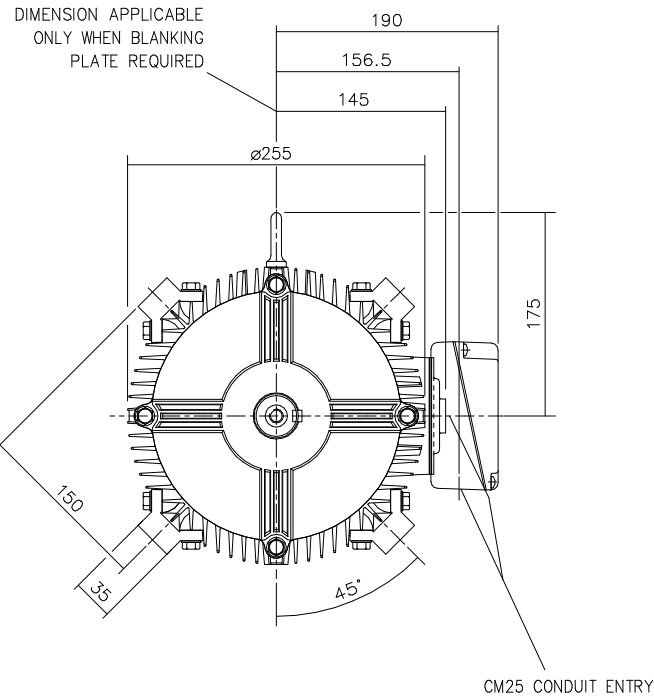
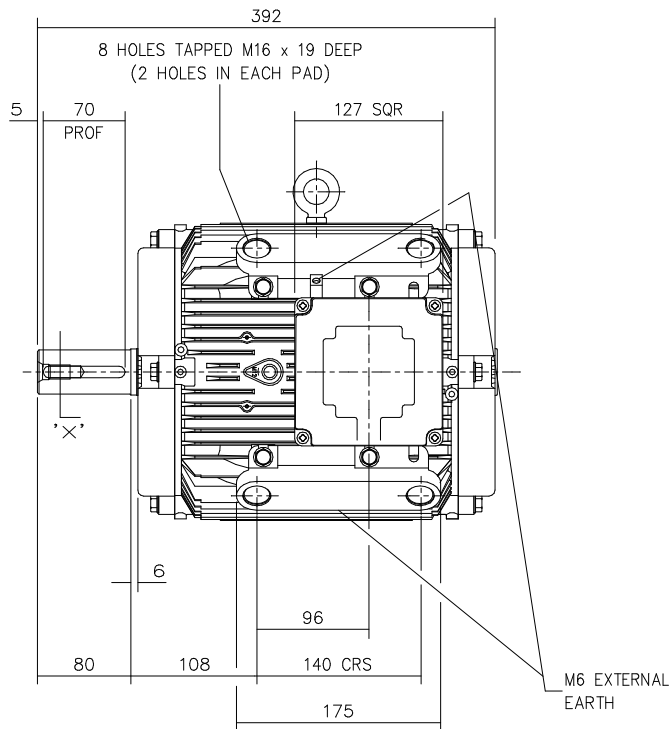

TERMINAL BOX POSITION: - CAN BE ARRANGED AT EITHER 9,12 OR 3 O'CLOCK.
STANDARD TERMINAL BOX POSITION IS 3 O'CLOCK AS SHOWN.
CONDUIT ENTRIES: - TERMINAL BOX CAN BE ROTATED AT 90° INTERVALS
(CONDUIT ENTRY POSITION SHOWN FOR ILLUSTRATION ONLY).

CUSTOMER		
ORDER No.		
PART No.		
OUR ORDER No.		
FRAME SIZE		
KW.	RPM.	
Hz	PHASE	
VOLTS	POLES	
BRGS.	DE.	NDE.
MOTOR NETT WT.	Kg.	
SPECIAL REMARKS		

ALL DIMENSIONS IN MILLIMETRES.



BROOK CROMPTON

Huddersfield, HD1 3LJ
ENGLAND

SHEET SIZE	TITLE
A3	OUTLINE DIMENSION DRAWING W ALUMINIUM TOTALLY ENCLOSED NO FAN 132S/M FRAME PAD MOUNTED MOTOR

	NAME	DATE
DRAWN	MI	20-09-94
CHECKED	JWD	20-09-94
SCALE	1:4	

DRG. No.	W28GP000/3	
DRG. REF.		
REVISION:	DH	DATE 05/08/03